

D-060-C HF SB 285 psi

D-062 HF SB 360 psi

Underground Air Valve System for Potable Water



Description

The D-060-C HF SB is a complete product package that combines the reliable and efficient properties of the A.R.I. D-060-C HF Combination Air Valve with the added feature of a sub-surface valve that can be buried below ground. A specially designed gear box operated horizontal sliding disc valve - situated at the base of the D-060-C HF SB assembly - allows for the air valve disconnection and maintenance from ground level.

This gear box operated shut-off valve is equipped with a safety mechanism enabling disconnection and removal of the D-060 air valve from its subsurface housing, even when the system is under pressure. Since service and maintenance operations of the unit are performed entirely from the surface, there is no need for safety considerations associated with confined space entry.

The D-060-C HF Combination Air Valve has the features of both an air release valve and an air & vacuum valve.

The air release component is designed to automatically release small pockets of air to the atmosphere as they accumulate along a pipeline or piping system when it is full and operating under pressure.

The air & vacuum component is designed to automatically discharge or admit large volumes of air during the filling or draining of a pipeline or piping system. This valve will open to relieve negative pressures whenever water column separation occurs.

Applications

- Municipal and industrial water conveyance systems.

Operation

The air & vacuum component, with the large orifice, discharges air at high flow rates during the filling of the system and admits air into the system at high flow rates during its drainage and at water column separation.

High velocity air will not blow the float shut. Water will lift the float which seals the valve.

At any time during system operation, should internal pressure of the system fall below atmospheric pressure, air will enter the system.

The smooth discharge of air reduces pressure surges and other destructive phenomena.

The intake of air in response to negative pressure protects the system from destructive vacuum conditions and prevents damage caused by water column separation. Air entry is essential to efficiently drain the system.

The air release component releases entrapped air in pressurized systems.

Without air valves, pockets of accumulated air may cause the following hydraulic disturbances:

- Restriction of effective flow due to a reduction of the flow area. In extreme cases this will cause complete flow stoppage.
- Obstruction of efficient hydraulic transmission due to air flow disturbances.
- Acceleration of cavitation damages.
- Increase in pressure transients and surges.
- Internal corrosion of pipes, fittings and accessories.
- Dangerous high-energy bursts of compressed air.
- Inaccuracies in flow metering.

As the system fills and is pressurized, the combination air valve functions in the following stages:

1. Air in the pipeline is discharged by the air valve.
2. Liquid enters the air and vacuum component, lifting the float to its sealing position.
3. Water enters the air release component of the valve, lifting the float and pushing the rolling seal to its sealing position.
4. Entrapped air, accumulating at peaks and along the system, rises to the top of the air release valve, displacing the liquid in the valve's body.
4. The float drops, unsealing the rolling seal. The air release orifice opens and the accumulated air is released.
5. Liquid replaces the air released from the valve, buoying up the float and pushing the rolling seal back to its sealing position.

When internal pressure falls below atmospheric pressure (negative pressure):

1. The floats will drop down, immediately opening the air & vacuum and air release orifices.
2. Air will enter into the system.

Main Features

D-060-C HF SB Underground Air Valve System for Potable Water:

- The D-060-C HF SB incorporates an integral, flat, gear box operated horizontal sliding disc valve with a 2", 3" full bore passage.
- The shut-off valve is operated from the surface.
- Pressure is automatically released from the air valve when the sliding disc valve is closed.
- The quick connector between the adaptor and the shut-off valve facilitates detachment during handling.
- The integrated assembly handle eases the process of lifting the air valve assembly out from the valve box.
- Pipe connections: 3" threaded (NPT) or flanged, in accordance with all standards.

- Safety elements: Disengaging the air valve is safeguarded: unless the shut-off valve is in the “closed” position and the internal pressure is released, it is not possible to extract the air valve.
- All parts are corrosion resistant: Metal parts made of Stainless Steel, Ductile Iron or Steel, Composite material parts made of Nylon.
- Drainage system: a special one-way valve that drains the water from the valve box and does not admit water.

Combination Air Valve:

- Working pressure range: D-060-C HF: 3 - 285 psi.
D-062 HF: 3 - 360 psi
- Testing pressure for the air valve is 1.5 times its working pressure.
- Maximum working temperature: 140° F.
- Maximum intermittent temperature: 194° F.
- All main flow cross-sections are equal or greater than the nominal port area.
- Aerodynamic design enables high flow rates of air both at intake and at discharge.
- Reliable operation reduces water hammer incidents.
- Dynamic design allows for high capacity air discharge while preventing premature closure.
- Special orifice seat design: Stainless Steel SAE 316 and E.P.D.M. rubber, assures long-term maintenance-free operation.
- Screen protected outlet.
- The upper screen is protected with a protective cover.
- FBE coating, both interior & exterior, in accordance with the standard DIN 30677-2.

Air Release Component

- Body made of high strength materials.
- All operating parts are made of specially selected corrosion- resistant polymer materials.
- Large size air release orifice:
 1. Dramatically reduces the possibility of obstruction by debris.
 2. Discharges high air flow rates.
 3. One size orifice for a wide pressure range (up to 360 psi), achieved by the rolling seal mechanism.

Advantages and Benefits

- Relatively lightweight and convenient to install.
- Sub-surface installation.
- Low installation costs:
- No need for expensive, large excavation.
- No need for expensive, human-accessible manholes.
- Low maintenance costs:
- No need for specialized tools or safety equipment.
- One person for operation and maintenance.
- Clean and environmentally friendly.
- Safe in operation:
- Greatly reduces danger of contact with local fauna – snakes and scorpions, etc!
- Entirely operated and maintained from ground level.
- Reliable and efficient operation:
 - Dynamic design allows high velocity air discharge while preventing premature closure.
 - Unique Rolling Seal mechanism.
 - Since the valve is a sub-surface (underground), it is more resistant to frost conditions.

Valve Selection

- Two different installation lengths:
 1. 31.7 inch tube; complete system length: 36.8 inch.
 2. 39.6 inch tube; complete system length: 44.6 inch.

Note

For best suitability, it is recommended to send the fluid chemical properties along with the valve request.

Upon ordering, please specify: model, size, working pressure, threads standard and type of liquid.

UNDERGROUND AIR VALVE SYSTEM PARTS LIST AND SPECIFICATION

No	Part	Material
1.	Vent Outlet	Polyethylene
2.	Valve Box Cover	Polyethylene
3.	Lifting Handle	Stainless Steel SAE 304
4.	Operating Rod	Stainless Steel SAE 304
5.	D-060-C HF Air Valve	see below
6.	Sliding Disc Valve	DI + STST+ EPDM /STST+STST+ EPDM
7.	Adaptor - Quick Connector	Stainless Steel SAE 316
8.	Safety Handle	Stainless Steel SAE 316
9.	Pressure Release Outlet	Stainless Steel SAE 316
10.	Valve Box	Polyethylene
11.	"T" Key	Stainless Steel SAE 304
12.	Flange 3" 4"	Reinforced Nylon / Stainless Steel SAE 316
13.	Drainage One Way Valve Connection	Polypropylene + Acetal

A.V. PARTS LIST AND SPECIFICATION

No.	Part	Material
1.	Shell S-050-C	Ductile Iron ASTM A-536 60-40-18 / Resicoat RT R4
	Shell S-052	Ductile Iron ASTM A536 60-40-18 / Resicoat RT R4
2.	Body	NSF 61 Certified Reinforced Nylon
3.	One Way Out	Brass
4.	Rolling Seal	
	285/360 psi	NSF 61 Certified E.P.D.M
	87 psi	Silicone
5.	Clamping Stem	NSF 61 Certified Reinforced Nylon
6.	Float	NSF 61 Certified Foamed Polypropylene
7.	O-Ring	NSF 61 Certified NBR 70
8.	Base	Stainless Steel ASTM A744 CF8M
9.	Plug	Stainless Steel SAE 316
10.	Domed Nut & Washer	NSF 61 Certified STST UNS 31600
11.	Screen Cover	Cast Iron ASTM A48 CL.35B / Resicoat RT R4
12.	Screen	NSF 61 Certified STST UNS 30400
13.	Bolt, Nut & Washer	NSF 61 Certified STST UNS 31600
14.	Cover	Ductile Iron ASTM A536 60-40-18 / Resicoat RT R4
15.	Orifice Seat	Stainless Steel SAE 316 / UNS 31600
16.	Orifice Seal	NSF 61 Certified E.P.D.M
17.	O - Ring	NSF 61 Certified NBR 70
18.	Float	NSF 61 Certified STST UNS 31600 /NSF 61 Certified polycarbonate
19.	Plug	Stainless Steel SAE 316
20.	Body	Ductile Iron ASTM A536 60-40-18 / Resicoat RT R4

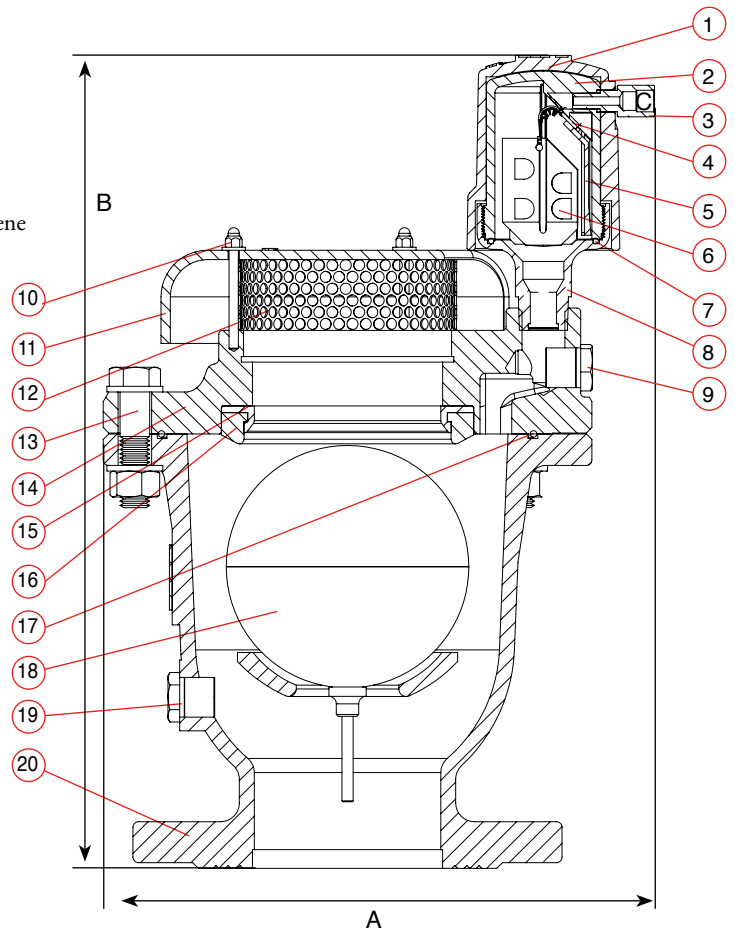
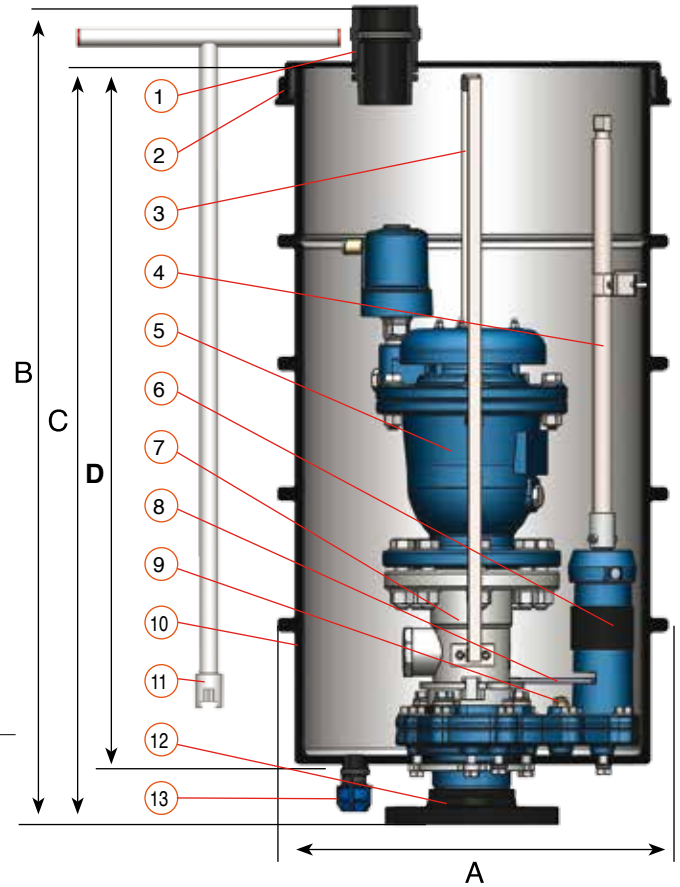

AIR & VACUUM FLOWRATE

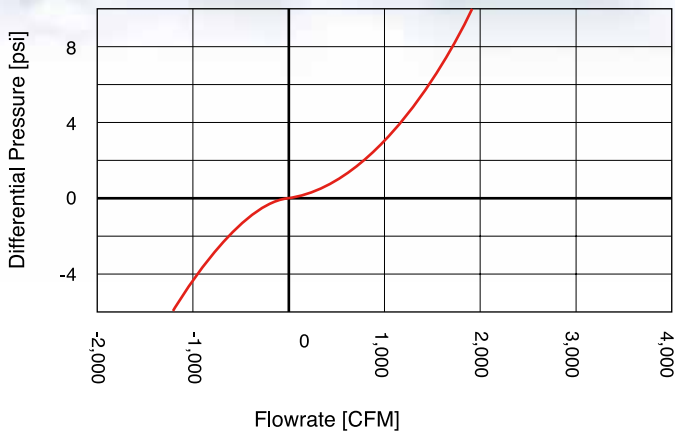

AIR RELEASE FLOWRATE

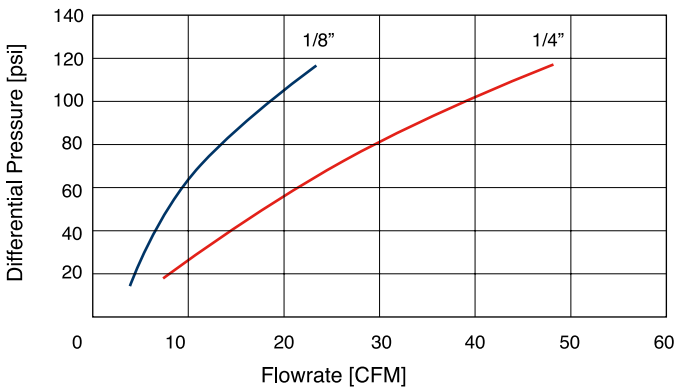

Sample Installation Scheme



Prior to site preparation and installation, please refer to the D-060-C HF SB Installation and Maintenance Manual for all the relevant instructions and information. The manual can be obtained by contacting the A.R.I marketing dept. or downloading the file from our website.

DIMENSIONS AND WEIGHTS

Model	Dimensions Inch.				Weight Lbs.
	A	B	C	D	
D-060-C SB 32	17.6	37.0	34.4	31.7	133.6
D-060-C SB 40	17.6	44.9	42.3	39.6	141.1