

S-025 150 PSI



Automatic Air Release Valve for Wastewater - Short Version

Description

The S-025 Automatic Air Release Valve is specifically designed to operate with liquids carrying solid particles such as wastewater and effluent.

The valve's unique design enables the separation of the liquid from the sealing mechanism and assures optimum working conditions.

The valve releases accumulated air (gases) from the system while it is operating under pressure.

The presence of air in a wastewater system can reduce the effective cross sectional flow area, resulting in increased head loss and decreased flow.

Unwanted air may also cause water hammer, metering inaccuracies and internal corrosion.

Applications

- Wastewater & water treatment plants.
- Wastewater and effluent water transmission lines.

Operation

A.R.I. model S-025 is an air release valve for wastewater systems.

As the system fills and is pressurized, the automatic air release valve functions according to the following stages:

1. When the liquid level reaches the valve's lower portion, the lower float is lifted, pushing the sealing mechanism to its sealing position.
2. The entrapped air is confined in a pocket between the liquid and the sealing mechanism. The air pressure is equal to the system pressure.
3. Increases in system pressure compress the trapped air in the upper section of the conical chamber. The conical shape assures the height of the air gap. This enables separation of the liquid from the sealing mechanism.
4. Entrapped air (gas), accumulating at peaks and along the system, rises to the top of the valve, and displaces the liquid in the valve's body.
5. When the liquid level is lowered to a point where the float is no longer buoyant, the float drops, unsealing the rolling seal. The air release orifice opens and allows part of the air that accumulated in the upper portion of the valve to be released to the atmosphere.
6. Liquid enters the valve. The float rises, pushing the rolling seal to its sealing position. The remaining air gap prevents the wastewater from fouling the mechanism.

Note: Automatic air release valves are designed to release air as it accumulates at peaks in pressurized systems. They are not normally recommended for vacuum protection or for discharging large volumes of air, because of their inherently small orifices. For this purpose, air & vacuum valves are recommended as they have much larger orifices.

However, air release valves will permit air to enter the system under vacuum conditions. If this is not desirable, specify the one-way out

check valve.

Main Features

- Working pressure range: 3 - 150 psi
- Testing pressure: 250 psi
- Maximum working temperature: 140° F.
- Maximum intermittent temperature: 194° F.
- The unique design of the valve prevents contact between the wastewater and the sealing mechanism by creating an air gap at the top of the valve. These features are achieved by:
 - The conical body shape: designed to maintain the maximum distance between the liquid and the sealing mechanism and still obtain minimum body length.
 - Independent spring-guided linkage between the lower float/rod assembly and the upper float sealing mechanism: allows free movement of the float and rod. Vibrations and movement of the lower float due to turbulence will not unseat the upper float sealing mechanism
 - The Rolling Seal Mechanism: less sensitive to pressure differentials than a direct float seal. It accomplishes this by having a comparably large orifice for a wide pressure range (up to 10 bar).
 - Funnel-shaped lower body: designed to ensure that residue wastewater matter will fall back into the system and be carried away by the main pipe.
- All inner metal parts made of stainless steel. Float made of composite materials.
- Threaded discharge outlet enables connection to a vent hose/pipe.
- 1/4" ball valve releases trapped pressure and drains the valve body prior to maintenance and for back-flushing during maintenance.

Valve Selection

- These valves are available in 2", with a NPT male threaded connection or flanged ends to meet ASA 150 standard or any requested standard.
- With a One-way, Out-only attachment, allows for air release only, prevents air intake.
- For best suitability, it is recommended to send the fluid chemical properties along with the valve request.

Note

- The S-025 air valve is intended for use with raw wastewater. For use with aggressive liquids, please consult with our application engineers or with the marketing dept.
- For best suitability, it is recommended to send the fluid chemical properties along with the valve request.
- Upon ordering, please specify: model, size, working pressure, thread and flange standard and type of liquid.

DIMENSIONS AND WEIGHTS

Inlet Size	Dimensions Inch		Connection C	Weight Lbs.	Orifice Area Sq.In.
	A	B			
2" Threaded	9.7	16.7	1/8" NPT Female	8.4	0.018
2" Flanged	9.7	16.9	1/8" NPT Female	9.2	0.018

PARTS LIST AND SPECIFICATION

No. Part	Material
1. Discharge Outlet	Polypropylene
2. Rolling Seal	E.P.D.M.
3. Body	Reinforced Nylon
4. Clamping Stem	Reinforced Nylon
5. Float	Foamed Polypropylene
6. O-Ring	BUNA-N
7. Adaptor	Acetal
8. O-Ring	BUNA-N
9. Body	Reinforced Nylon
10. Float Assembly	Stainless Steel SAE 316 + Foamed Polypropylene
11. Clamp	Reinforced Nylon + Stainless Steel SAE 316
12. Base	Reinforced Nylon
13. Ball Valve 1/4"	Stainless Steel SAE 316

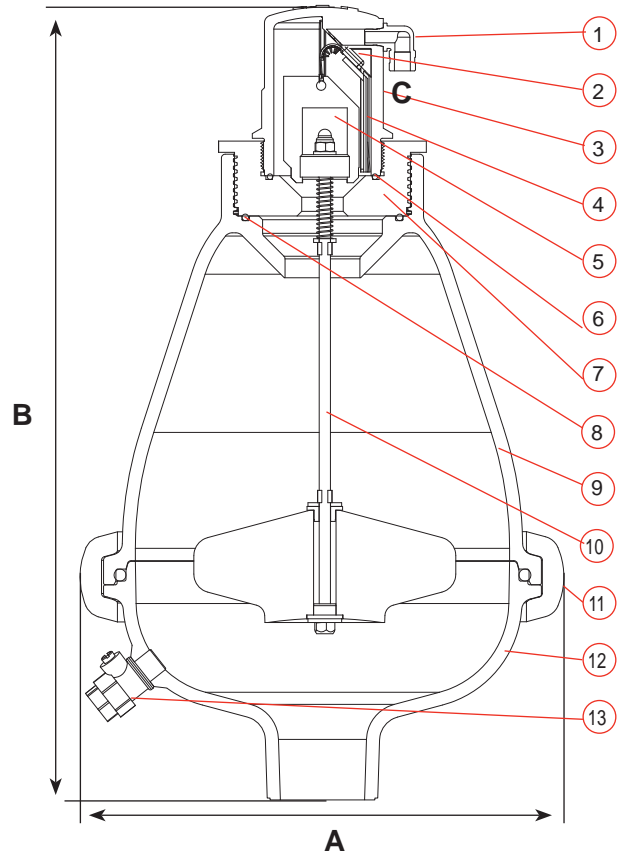

AIR RELEASE FLOWRATE

