

SB UNDERGROUND AIR VALVE ASSEMBLY

INTRODUCTION

The A.R.I. Underground Air Valve System for water conveyance systems is a complete package that combines the reliable and efficient properties of the A.R.I. air valve with the added feature of a sub-surface valve that is buried below ground. A specially designed shut-off valve - situated at the base of the Air Valve Assembly: - allows maintenance from ground level. The shut-off disc valve is equipped with a safety mechanism enabling disconnection and removal of the air valve from its sub-surface housing when the system is under pressure. Since service and maintenance operations of the unit are performed entirely from the surface, there is no need for the safety considerations associated with confined space entry.

FEATURES

- A combination air valve, with a large air/vacuum orifice and a small automatic air release orifice, integrated into one body.
- The air valve inlet diameter is 3". Available also in 2"
- Pipe connections: 3" threaded (NPT) or flanged, in accordance with ASA standards.
- The integral, flat, gear box driven shut-off disc valve has an 3" full bore passage.
- The shut-off valve is operated from the surface.
- All connections are quick connections including the adaptor connection to the shutoff valve.
- Safety elements: Disengaging the air valve is safeguarded - unless the shut-off valve is in "closed" position, and the internal pressure is released, it is not possible to extract the air valve.
- All parts are corrosion resistant: Metal parts - made of St.St.316 and coated ductile iron, composite material parts – made of reinforced nylon, PE, PVC.
- Working pressure range: 3-360 psi
- Maximum working temperature: 140° F.
- Maximum intermittent temperature: 194° F.

INSTALLATION

It is recommended to install the unit simultaneously with the installation of the pipeline. This will preclude the need to excavate later, when the line is already in place.

Before beginning installation: Remove the Air Valve Assembly from the Valve Box (see removal instructions below). The unit will be lighter and easier to handle and install.

Before installing, make sure the unit cover is in place – this prevents soil, media or dirt from falling into the unit.



REMOVAL OF THE AIR VALVE ASSEMBLY FROM THE VALVE BOX

1. Close the Disc Valve (8) by attaching the "T" Key (1) to the upper end of the Operator Rod (4) and turning fully in a clockwise direction.
2. Unlock the Air Valve Assembly by rotating the Frame (3) of Air Valve Assembly in a clockwise direction - see Fig. 1B, 1C.
3. Lift and remove the Air Valve Assembly from the Valve Box (5).

HEIGHT

The distance from the top surface of the Valve Box Cover (2) to the bottom of the access cover {h1} should be between 5 cm (2") and 20 cm (8"). From this point the overall height {H} of the unit from the pipeline flange or riser flange will be measured (See Fig. 3).

Care must be taken that the unit is installed at a perpendicular angle to the horizontal.

BORE DIAMETER AND DEPTH

The bore diameter {d1} should be at least 40". This will allow at least 12" for the filling material around the Valve Box (5) (See Fig. 3).

The height of the flange on the pipe line or riser should allow the cover of the unit to be situated as defined in the previous section (HEIGHT). If this is not possible then an extender/riser must be attached and the flange of the unit fastened to it.

Diagonal riser: If the unit is to be installed on a riser that is at an angle, the diagonal slope should be at least 7° - (See Fig. 4).

In the case of a diagonal riser, it is advisable to install the riser with an air/gas trap (See Fig. 4).

FILLING

The unit must be surrounded with a fine grained filling material such as sand or very fine gravel (in accordance with local standards and by-laws). The filling material must be of a type that will not expand when absorbing water. (See Fig. 3).

CAUTION

- DO NOT use clay or similar materials – These will expand on absorption of water.
- DO NOT use filling materials that contain sharp objects such as rocks and bricks or pieces of metal or glass.

INSERTION OF THE AIR VALVE ASSEMBLY INTO THE VALVE BOX

CAUTION

DO NOT OPEN the shut-off disc valve (8) until the air valve assembly is locked in its place.

1. Before inserting the Air Valve Assembly, visually inspect the two O-Rings (7) at the base of the assembly. If damaged, they must be replaced. Clean and lubricate the O-Rings lightly with silicon-based lubricant.
2. Insert the Air Valve Assembly into the Disc Valve (8).
4. Lock the Air Valve Assembly into the Disc Valve by rotating the Frame (3) of the Air Valve Assembly in a counterclockwise direction - see Fig. 1B, 1A
5. Place the "T" Key (1) inside the Valve Box (5) prior to closing the unit – close the Valve Box Cover (2) tightly on the Valve Box

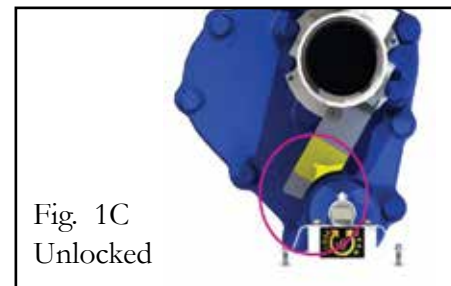
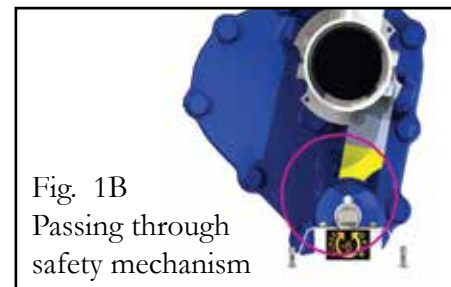
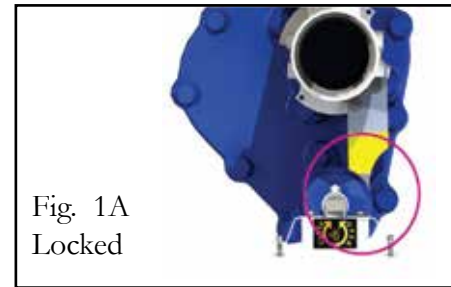

INITIAL OPERATION

1. Make sure that the Air Valve Assembly is in the locked position (the yellow indicator plate is positioned to the right of the gear box) - see Fig. 1A. Locking is carried out by holding the Frame (3) and rotating the Air Valve Assembly in a counterclockwise direction.
2. Open the Disc Valve (8) by fully turning the Operator Rod (4) in a counterclockwise direction.

OPERATION AND MAINTENANCE

The unit is designed so that all operation and maintenance can be carried out at ground level. To this purpose, the Air Valve Assembly is easy to extract from the Valve Box (5) and the Air Valve can be substituted very quickly with a pre-serviced replacement Air Valve. Alternatively, once extracted, the Air Valve can be serviced in-situ and returned into the Valve Box.

EXTRACTING THE AIR VALVE ASSEMBLY FOR MAINTENANCE

1. Remove the Valve Box Cover (2).
2. Close the Disc Valve (8) by attaching the "T" Key (1) to the upper end of the Operator Rod (4) and fully turning in a clockwise direction.
3. Unlock the Air Valve Assembly by rotating the Frame (3) of the Air Valve Assembly in a clockwise direction - see Fig. 1B, 1C.
4. Lift and remove the Air Valve Assembly from the Valve Box (5).
5. Perform maintenance on the Air Valve (Refer to the specific air valve maintenance manual found at the end of this IOM manual).

INSERTION OF THE AIR VALVE ASSEMBLY

CAUTION

DO NOT OPEN the shut-off disc valve (8) until the air valve assembly is fully locked in place

1. Before inserting the Air Valve Assembly, visually inspect the two O-Rings (7) at the base of the assembly; if damaged, these must be replaced. Clean and lubricate the O-Rings lightly with silicon based lubricant. Clean and remove debris from the housing area.
2. Insert the Air Valve Assembly into the Disc Valve (8).
3. Lock the Air Valve Assembly into the Disc Valve by rotating the Frame (3) of the Air Valve Assembly in a counterclockwise direction - see Fig. 1B, 1A
5. Continue by following instructions for – INITIAL OPERATION.

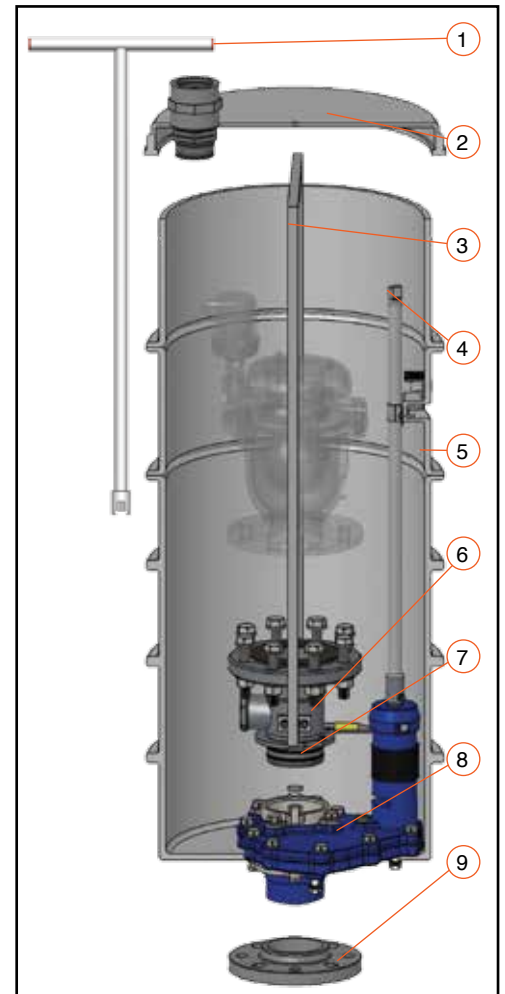

PARTS LIST

No.	Part
1.	"T" Key
2.	Valve Box Cover
3.	Frame
4.	Operator Rod
5.	Valve Box
6.	Adaptor - Quick Connector
7.	O-Rings
8.	Disc Valve
9.	Flange

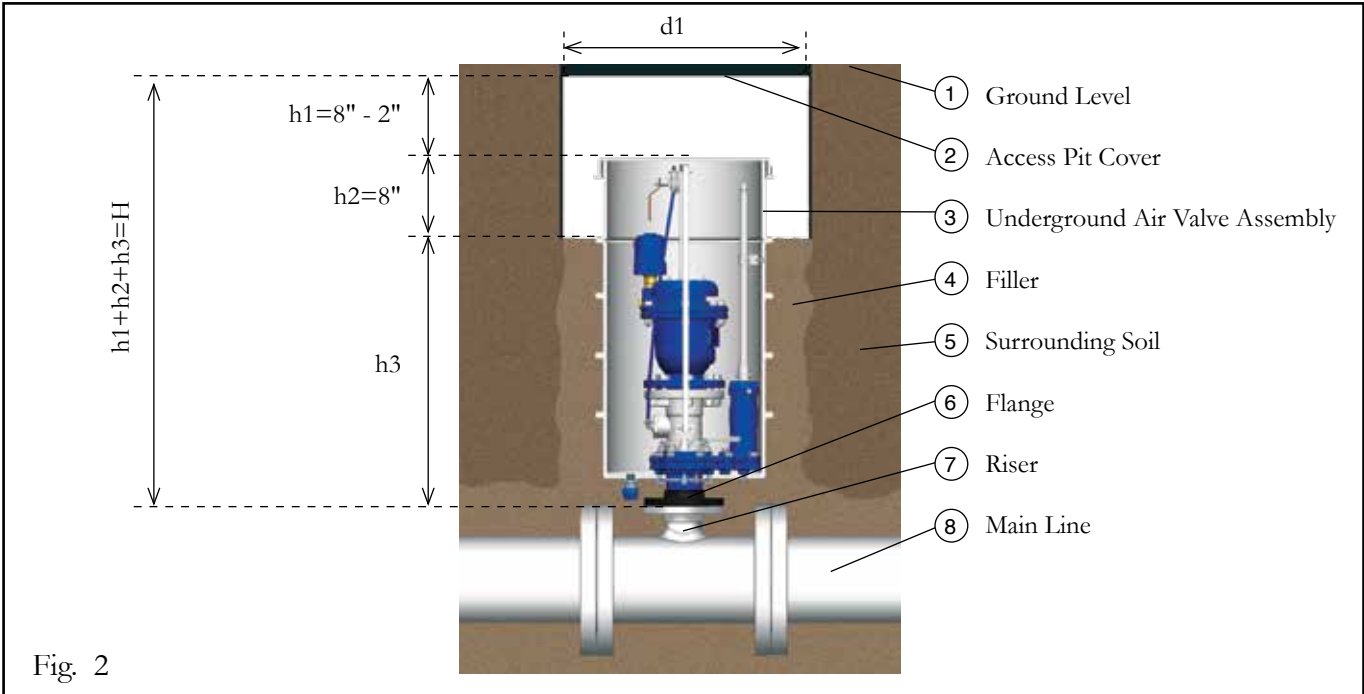

Fig. 2

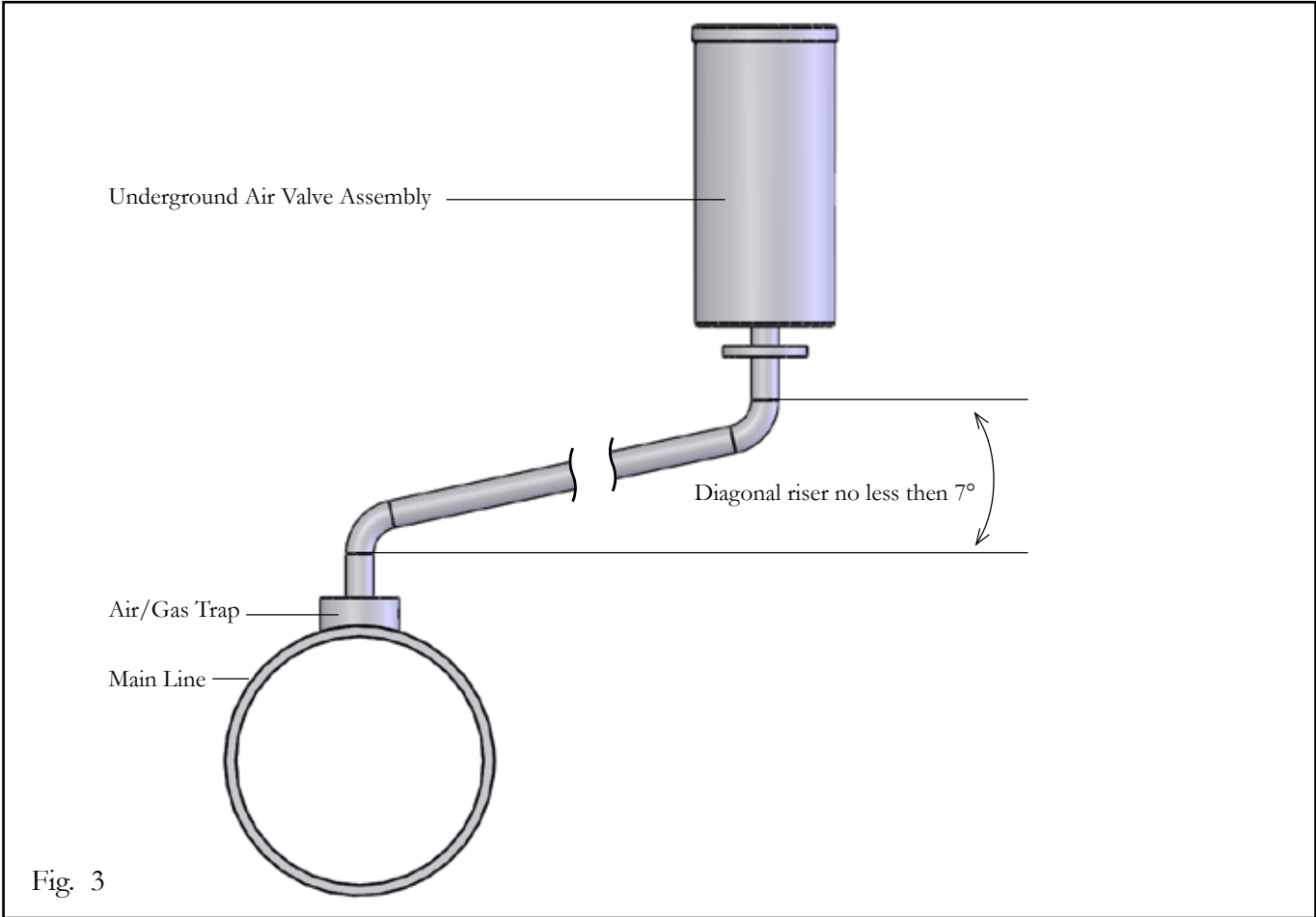

Fig. 3

PROBLEM	REASON	SOLUTION
1. The air valve assembly can't be removed from the disc valve	Mechanical interference	1. Rotate the Frame (3) of the Air Valve Assembly counterclockwise to the locked position (Fig. 1A) 2. Make sure that the Disc Valve is in the closed position 3. Rotate the Air Valve Assembly clockwise to the open position - see Fig. 1B, 1C.
2. The air valve continuously leaks water with the opening of the disc valve.	Air valve malfunction	1. Follow Instructions for REMOVAL OF THE AIR VALVE ASSEMBLY FROM THE VALVE BOX 2. Maintain the air valve (See specific air valve maintenance manual)

NOTE

Please contact your local representative with any clarifications, questions you may have regarding the instructions in this manual.

