

D-065 HF 580 psi

Combination Air Valve for High Flow



Description

The D-065-C HF series Combination Air Valve has the features of both an air release valve and an air & vacuum valve.

The air release component is designed to automatically release small pockets of air to the atmosphere as they accumulate along a pipeline or piping system when it is full and operating under pressure.

The air & vacuum component is designed to automatically discharge or admit large volumes of air during the filling or draining of a pipeline or piping system. This valve will open to relieve negative pressures whenever water column separation occurs.

Applications

- Municipal and industrial water conveyance systems.
- Water pipelines vulnerable to vandalism and/or water theft.
- Water systems found in remote areas.
- Water systems with pressure demands up to 580 psi.

Operation

The air & vacuum component, with the large orifice, discharges air at high flow rates during the filling of the system and admits air into the system at high flow rates during its drainage and at water column separation.

High velocity air will not blow the float shut. Water will lift the float which seals the valve.

At any time during system operation, should internal pressure of the system fall below atmospheric pressure, air will enter the system.

The smooth discharge of air reduces pressure surges and other destructive phenomena.

The intake of air in response to negative pressure protects the system from destructive vacuum conditions and prevents damage caused by water column separation. Air entry is essential to efficiently drain the system. The air release component releases entrapped air in pressurized systems.

Without air valves, pockets of accumulated air may cause the following hydraulic disturbances:

- Restriction of effective flow due to a reduction of the flow area. In extreme cases this will cause complete flow stoppage.
- Obstruction of efficient hydraulic transmission due to air flow disturbances.
- Acceleration of cavitation damages.
- Increase in pressure transients and surges.
- Internal corrosion of pipes, fittings and accessories.
- Dangerous high-energy bursts of compressed air.
- Inaccuracies in flow metering.

As the system starts to fill, the combination air valve functions according to the following stages:

1. Air in the pipeline is discharged by the valve.
2. Liquid enters the air & vacuum component, lifting the float to its sealing position.
3. Liquid enters the air release component of the valve, lifting the float and pushing the rolling seal to its sealing position.
4. Entrapped air, accumulating at peaks and along the system, rises to the top of the air release valve, displacing the liquid in the valve's body.
5. The float drops, unsealing the rolling seal. The air release orifice opens and the accumulated air is released.
6. Liquid replaces the air released from the valve, buoying up the float and pushing the rolling seal back to its sealing position.

When internal pressure falls below atmospheric pressure (negative pressure):

1. The floats will drop down, immediately opening the air & vacuum and air release orifices.
2. Air will enter the system.

Main Features

- Working pressure range: 3 - 580 psi.
- Testing pressure :
- Maximum working temperature: 140° F.
- Maximum intermittent temperature: 194° F.
- All main flow cross-sections are equal or greater than the nominal port area.
- Aerodynamic design enables high flow rates of air both at intake and at discharge.
- Reliable operation reduces water hammer incidents.
- Dynamic design allows for high capacity air discharge while preventing premature closure.
- Special orifice seat design: Stainless Steel and E.P.D.M. rubber, assures long-term maintenance-free operation.
- Screen protected outlet.
- The upper screen is protected with a protective cover.

Air Release Component

- Body made of high strength materials.
- All operating parts are made of specially selected corrosion- resistant polymer materials.
- Large size air release orifice:
 - Dramatically reduces the possibility of obstruction by debris.
 - Releases air at high flow rates.

- One size orifice for a wide pressure range (up to 580 psi), achieved by the rolling seal mechanism.

Valve Selection

- Size Range: 2" - 8"
- These valves are manufactured with flanged ends to meet ASA 300, ASA 600 standard or any requested standard.
- Valve coating: Fusion bonded epoxy coating in accordance with the standard DIN 30677-2.
- Other coatings are available upon request.
- The air release component and the air & vacuum component are available as separate units.

Note

For best suitability, it is recommended to send the fluid chemical properties along with the valve request.
Upon ordering, please specify: model, size, working pressure, thread and flange standard and type of liquid.

AIR & VACUUM FLOWRATE

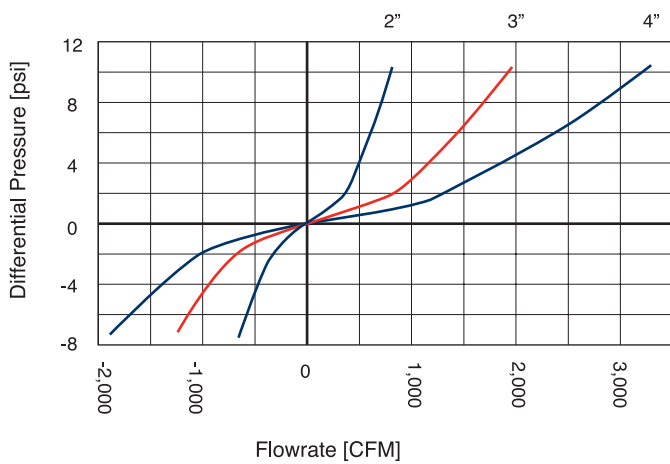

AIR & VACUUM FLOWRATE

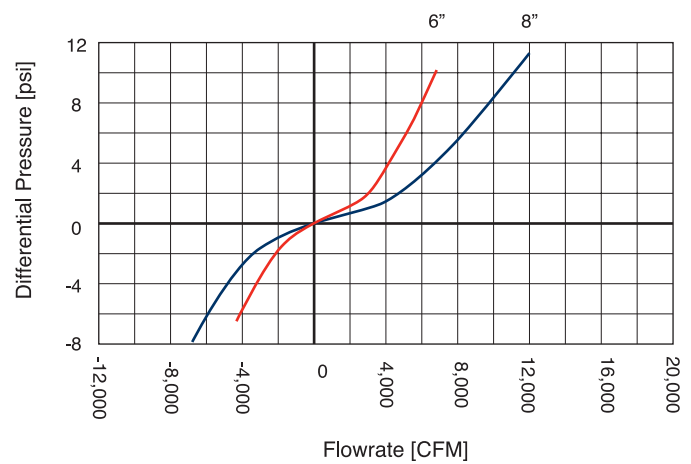

AIR RELEASE FLOWRATE

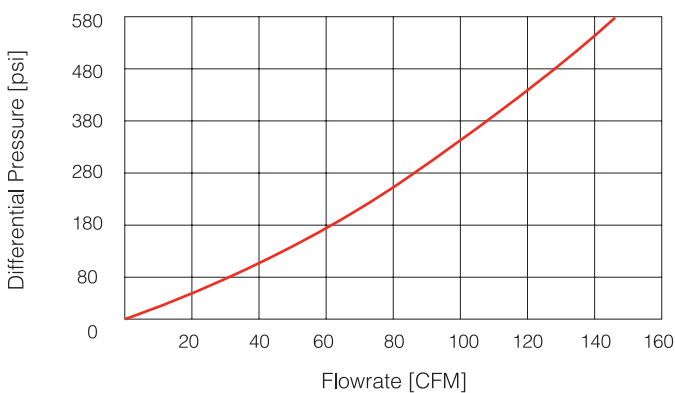

DIMENSIONS AND WEIGHT

Nominal Size	Dimensions Inch		Connection C	Weight Lbs.	Orifice Area Sq.In.	
	A	B			A / V	Air Rel.
2"	10.0	19.0	1/4" NPT	34.7	3.04	0.023

PARTS LIST AND SPECIFICATION FOR 2"

No.	Part	Material
1.	Discharge Outlet	PVC
2.	Rollpin	Stainless Steel SAE 304
3.	O-RING	BUNA-N
4.	Orifice	Reinforced Nylon
5.	Cover	Ductile Iron ASTM A536 60-40-18
6.	Rollpin	Stainless Steel SAE 304
7.	Rolling Seal	E.P.D.M.
8.	Lever	Reinforced Nylon
9.	Rollpin	Stainless Steel SAE 304
10.	Bolt, Nut & Washer	NSF 61 Certified STST UNS 30400
11.	O-Ring	BUNA-N
12.	Float	Polycarbonate / Stainless Steel SAE 316
13.	Body	Ductile Iron ASTM A536 60-40-18
14.	Adaptor	Stainless Steel SAE 316
15.	Domed Nut & Washer	NSF 61 Certified STST UNS 30400
16.	Screen Cover	Ductile Iron ASTM A-536 60-40-18 / Resicoat RT R4
17.	Screen	NSF 61 Certified STST UNS 30400
18.	Plug	Stainless Steel SAE 316 / UNS 31600
19.	Cover	Ductile Iron ASTM A-536 60-40-18 / Resicoat RT R4
20.	O - Ring	NSF 61 Certified NBR 70
21.	Orifice Seat	Stainless Steel SAE 316 / UNS 31600
22.	Orifice Seal	NSF 61 Certified E.P.D.M
23.	Bolt & Nut	NSF 61 Certified STST UNS 30400
24.	Float	NSF 61 Certified STST UNS 31600
25.	Plug	Stainless Steel SAE 316 / UNS 31600
26.	Body	Ductile Iron ASTM A-536 60-40-18 / Resic

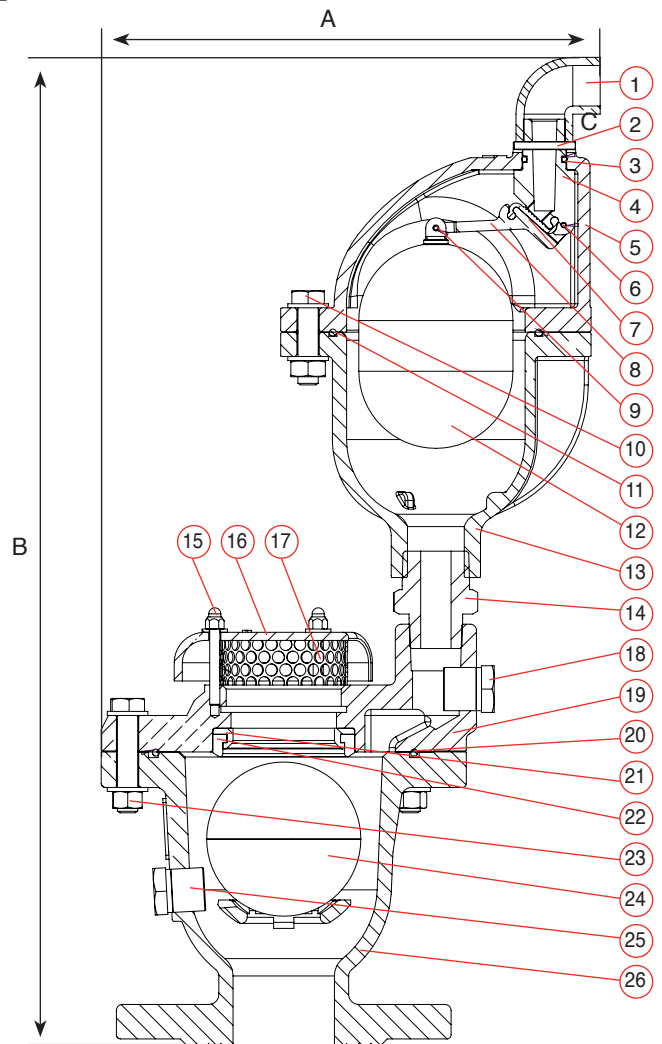

DIMENSIONS AND WEIGHT

Nominal Size	Dimensions Inch		Connection C	Weight Lbs.	Orifice Area Sq.In.	
	A	B			A / V	Air Rel.
3"	11.5	21.5	1/4" NPT	50.2	7.80	0.023

PARTS LIST AND SPECIFICATION FOR 3"

No.	Part	Material
1.	Discharge Outlet	PVC
2.	Rollpin	Stainless Steel SAE 304
3.	O-RING	BUNA-N
4.	Orifice	Reinforced Nylon
5.	Cover	Ductile Iron ASTM A536 60-40-18
6.	Rollpin	Stainless Steel SAE 304
7.	Rolling Seal	E.P.D.M.
8.	Lever	Reinforced Nylon
9.	Rollpin	Stainless Steel SAE 304
10.	Bolt, Nut & Washer	Ductile Iron ASTM A-536 60-40-18 / Resicoat RT R4
11.	O-Ring	BUNA-N
12.	Float	Polycarbonate / Stainless Steel SAE 316
13.	Body	Ductile Iron ASTM A536 60-40-18
14.	Adaptor	Stainless Steel SAE 316
15.	Domed Nut & Washer	NSF 61 Certified STST UNS 30400
16.	Screen Cover	Ductile Iron ASTM A-536 60-40-18 / Resicoat RT R4
17.	Screen	NSF 61 Certified STST UNS 30400
18.	Plug	Stainless Steel SAE 316 / UNS 31600
19.	Cover	Ductile Iron ASTM A-536 60-40-18 / Resicoat RT R4
20.	O - Ring	NSF 61 Certified NBR 70
21.	Orifice Seat	Stainless Steel SAE 316 / UNS 31600
22.	Orifice Seal	NSF 61 Certified E.P.D.M
23.	Bolt & Nut	NSF 61 Certified STST UNS 30400
24.	Float	NSF 61 Certified STST UNS 31600
25.	Plug	Stainless Steel SAE 316 / UNS 31600
26.	Body	Ductile Iron ASTM A-536 60-40-18 / Resic

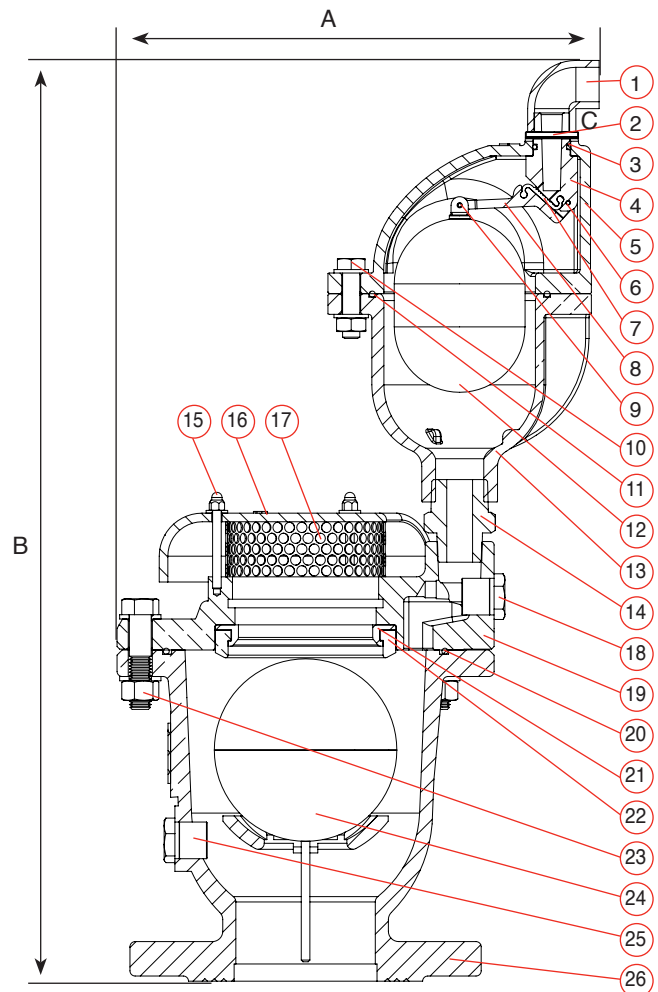

DIMENSIONS AND WEIGHT

Nominal Size	Dimensions Inch		Connection C	Weight Lbs.	Orifice Area Sq.In.	
	A	B			A / V	Air Rel.
4"	12.5	23.0	1/4" NPT	65.2	12.17	0.023

PARTS LIST AND SPECIFICATION FOR 4"

No.	Part	Material
1.	Discharge Outlet	PVC
2.	Rollpin	Stainless Steel SAE 304
3.	O-RING	BUNA-N
4.	Orifice	Reinforced Nylon
5.	Cover	Ductile Iron ASTM A536 60-40-18
6.	Rollpin	Stainless Steel SAE 304
7.	Rolling Seal	E.P.D.M.
8.	Lever	Reinforced Nylon
9.	Rollpin	Stainless Steel SAE 304
10.	Bolt, Nut & Washer	Stainless Steel SAE 316 / UNS 31600
11.	O-Ring	BUNA-N
12.	Float	Polycarbonate / Stainless Steel SAE 316
13.	Body	Ductile Iron ASTM A536 60-40-18
14.	Adaptor	Stainless Steel SAE 316
15.	Domed Nut & Washer	Stainless Steel SAE 316 / UNS 31600
16.	Screen Cover	Ductile Iron ASTM A-536 60-40-18 / Resicoat RT R4
17.	Screen	NSF 61 Certified STST UNS 30400
18.	Plug	Stainless Steel SAE 316 / UNS 31600
19.	Cover	Ductile Iron ASTM A-536 60-40-18 / Resicoat RT R4
20.	O - Ring	NSF 61 Certified NBR 70
21.	Orifice Seat	Stainless Steel SAE 316 / UNS 31600
22.	Orifice Seal	NSF 61 Certified E.P.D.M
23.	Bolt & Nut	NSF 61 Certified STST UNS 30400
24.	Float	NSF 61 Certified STST UNS 31600
25.	Plug	Stainless Steel SAE 316 / UNS 31600
26.	Body	Ductile Iron ASTM A-536 60-40-18 / Resic

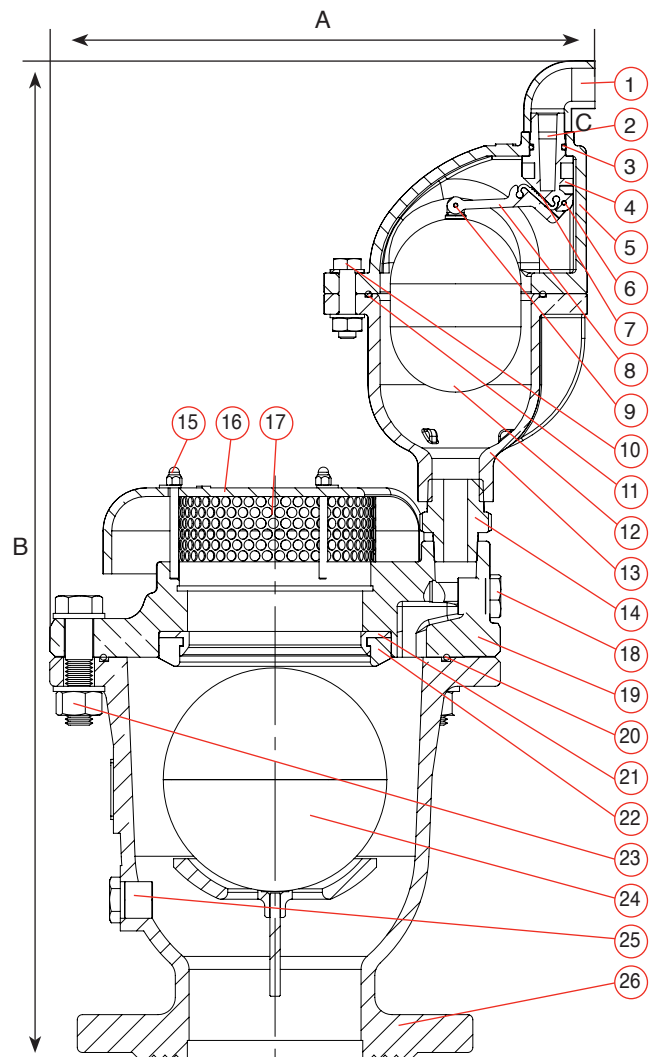

DIMENSIONS AND WEIGHT

Nominal Size	Dimensions Inch		Connection C	Weight Lbs.	Orifice Area Sq.In.	
	A	B			A / V	Air Rel.
6"	15.5	30.5	1/4" NPT	72.2	27.38	0.023

PARTS LIST AND SPECIFICATION FOR 6"

No.	Part	Material
1.	Discharge Outlet	PVC
2.	Rollpin	Stainless Steel SAE 304
3.	O-RING	BUNA-N
4.	Orifice	Reinforced Nylon
5.	Cover	Ductile Iron ASTM A536 60-40-18
6.	Rollpin	Stainless Steel SAE 304
7.	Rolling Seal	E.P.D.M.
8.	Lever	Reinforced Nylon
9.	Rollpin	Stainless Steel SAE 304
10.	Bolt, Nut & Washer	Steel, Zinc Cobalt Coated
11.	O-RING	BUNA-N
12.	Float	NSF 61 Certified Polycarbonate
13.	Body	Ductile Iron ASTM A536 60-40-18
14.	Lifting Ring	Carbon Steel
15.	Bolt & Washer	NSF 61 Certified STST UNS 30400
16.	Nut	NSF 61 Certified STST UNS 30400
17.	Screen Cover	Ductile Iron ASTM A-536 60-40-18 / Resicoat RT R4
18.	Screen	NSF 61 Certified STST UNS 30400
19.	Ring	Steel Din St.37
20.	Bolt	NSF 61 Certified STST UNS 30400
21.	Cover	Ductile Iron ASTM A-536 60-40-18 / Resicoat RT R4
22.	Orifice Seat	Stainless Steel SAE 316 / UNS 31600
23.	Orifice Seal	NSF 61 Certified E.P.D.M
24.	Float	NSF 61 Certified STST UNS 31600 / NSF 61 Certified polycarbonate
25.	Body	Ductile Iron ASTM A-536 60-40-18 / Resicoat RT R4
26.	Plug	Stainless Steel SAE 316 / UNS 31600
27.	Adaptor	NSF 61 Certified STST UNS 30400
28.	Nipple & Coupler	NSF 61 Certified STST UNS 30400
29.	Bolt & Washer	NSF 61 Certified STST UNS 30400
30.	O - Ring	NSF 61 Certified NBR 70
31.	Bolt & Washer	NSF 61 Certified STST UNS 30400
32.	Test Cock + Adaptor	Stainless Steel SAE 316 / UNS 31600
33.	O - Ring	NSF 61 Certified NBR 70

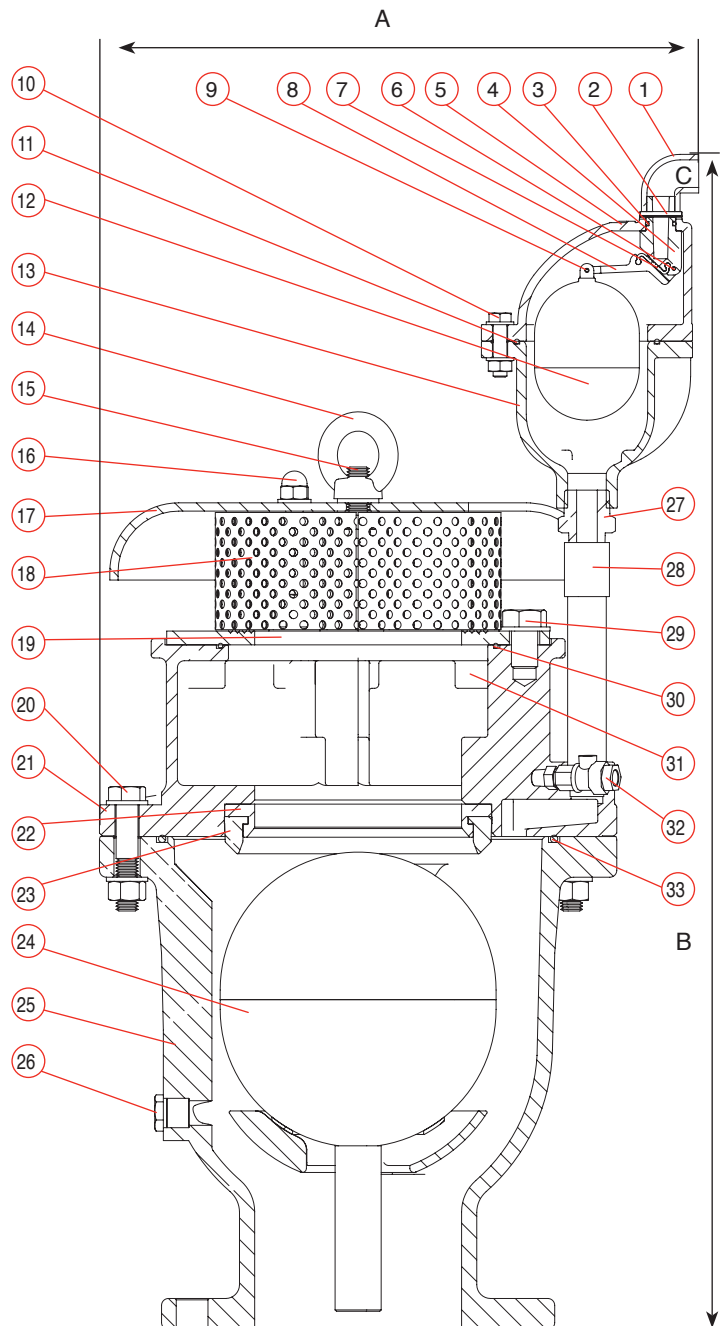

DIMENSIONS AND WEIGHT

Nominal Size	Dimensions Inch		Connection C	Weight Lbs.	Orifice Area Sq.In.	
	A	B			A / V	Air Rel.
8"	20.5	38.5	1/4" NPT	268.4	48.67	0.023

PARTS LIST AND SPECIFICATION FOR 8"

No.	Part	Material
1.	Discharge Outlet	PVC
2.	Rollpin	Stainless Steel SAE 304
3.	O-RING	BUNA-N
4.	Orifice	Reinforced Nylon
5.	Cover	Ductile Iron ASTM A536 60-40-18
6.	Rollpin	Stainless Steel SAE 304
7.	Rolling Seal	E.P.D.M.
8.	Lever	Reinforced Nylon
9.	Rollpin	Stainless Steel SAE 304
10.	Bolt, Nut & Washer	Steel, Zinc Cobalt Coated
11.	O-RING	BUNA-N
12.	Float	NSF 61 Certified Polycarbonate
13.	Body	Ductile Iron ASTM A536 60-40-18
14.	Lifting Ring	Carbon Steel
15.	Bolt & Washer	NSF 61 Certified STST UNS 30400
16.	Nut	NSF 61 Certified STST UNS 30400
17.	Screen Cover	Ductile Iron ASTM A-536 60-40-18 / Resicoat RT R4
18.	Screen	NSF 61 Certified STST UNS 30400
19.	Ring	Steel Din St.37
20.	Bolt	NSF 61 Certified STST UNS 30400
21.	Cover	Ductile Iron ASTM A-536 60-40-18 / Resicoat RT R4
22.	Orifice Seat	Stainless Steel SAE 316 / UNS 31600
23.	Orifice Seal	NSF 61 Certified E.P.D.M
24.	Float	NSF 61 Certified STST UNS 31600 / NSF 61 Certified polycarbonate
25.	Body	Ductile Iron ASTM A-536 60-40-18 / Resicoat RT R4
26.	Plug	Stainless Steel SAE 316
27.	Adaptor	NSF 61 Certified STST UNS 30400
28.	Nipple & Coupler	NSF 61 Certified STST UNS 30400
29.	Bolt & Washer	NSF 61 Certified STST UNS 30400
30.	O - Ring	NSF 61 Certified NBR 70
31.	Bolt & Washer	NSF 61 Certified STST UNS 30400
32.	Test Cock + Adaptor	Stainless Steel SAE 316 / UNS 31600
33.	O - Ring	NSF 61 Certified NBR 70

