

## MULTI-FUNCTIONAL COMBINATION AIR VALVE MODEL D-070-P

### GENERAL

1. The periodic maintenance of the air valve is an integral part in the proper regimen of water pipeline maintenance.
2. The air valve should be maintained at least once a year in accordance with the quality of the water and the types of fluid composition in the system.

### DISCLAIMER

A.R.I. FLOW CONTROL ACCESSORIES LTD. ("A.R.I.") shall NOT assume any liability and/or for any damage that may be caused to any person and/or property unless the MULTI-FUNCTIONAL COMBINATION AIR VALVE MODEL D-070-P ("Air Valve") has been duly installed and thereafter maintained in strict compliance with these Maintenance Instructions and/or any other installation and operation manuals provided by A.R.I. for the Air Valve and/or applicable ordinances and/or codes.

### INSTALLATION

Before installing the Model D-070-P air valve, make sure to flush and drain the pipeline of all dirt and solids that may be in the line.

**Installation of an isolating valve:** An isolating valve shall be installed under each air valve to enable the performance of periodic maintenance.

**Installation of a riser:** It is recommended to install the Model D-070-P air valve on top of a riser (see Fig.1). Diameter and height of the riser should be according to the following table (also see Fig. 2):

$d=D$  for  $D \leq 12"$ .  
 $d=0.6D$  for  $12" < D \leq 60"$ .  
 $d \geq 0.35D$  for  $D > 60"$ .  
 $h \geq D/2$  and  $h \geq 6"$ .

**Manifold:** When the valve is installed on a manifold, the air valves should be installed only on a welded manifold. They should be installed with the Discharge Outlet/Drainage Elbow openings facing in opposite directions (Fig. 2).

### OPERATION

**WARNING Water Discharge:** The normal operation of the air valve includes the discharge of water under pressure. Install the D-070-P so the Discharge Outlet with the attached Drainage Elbow is not directed toward electrical elements (pumps) or people.

#### DISCHARGE OUTLET – DRAINAGE ELBOW

**Drainage Elbow:** It is mandatory that a Drainage Elbow be installed at the Discharge Outlet (#1); the diameter of the Drainage Elbow shall be at least the diameter of the Discharge Outlet #1 (Fig. 1). The Drainage Elbow is supplied as standard with the D-070P air valve.

**Caution:** Do not put hands or objects into the Discharge Outlet#1 (Fig. 1).

**Air Gap:** A Drainage Elbow should be connected directly to the Discharge Outlet of the air valve (see Fig. 3). The outlet side of the Drainage Elbow must remain completely open and unobstructed (see Fig. 3).

An air gap of at least 2D of the air valve orifice must be maintained below the outlet of the Drainage Elbow. DO NOT connect a drain pipe directly to the Drainage Elbow. A drainage collector can be used below the air gap to collect and direct the water emissions to the drainage pipe (see Fig. 3).

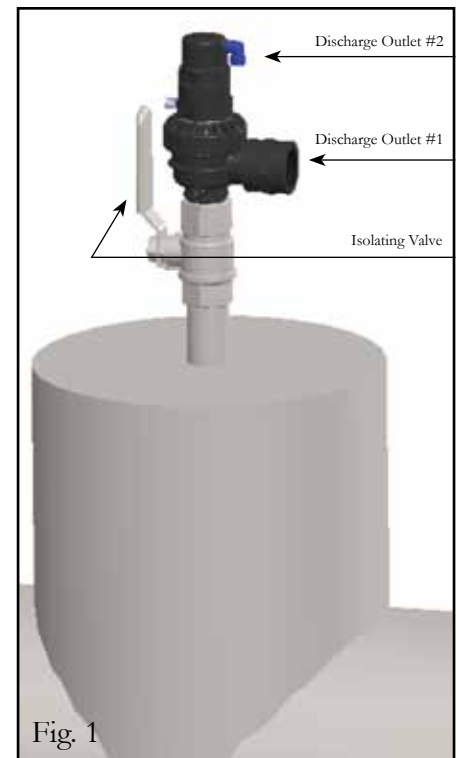

Fig. 1

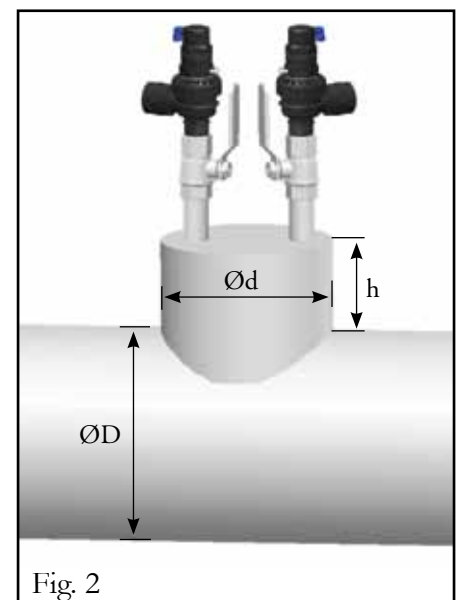

Fig. 2

## PERIODIC MAINTENANCE

The purpose of periodic maintenance: check integrity of the seals and clean the sealing areas.

The frequency of maintenance will be determined by the condition of the water system – weekly, monthly, quarterly etc.

### MANDATORY STEPS PRIOR TO MAINTENANCE

Perform the following steps prior to maintenance or removal of the air valve from the pipeline:

1. Shut the isolating valve (Fig.1) on the riser below the air valve.
2. Slowly open the Locking Ring (13) until water and air start to be released. Wait until all the water and air cease to be released before continuing
3. Continue to open the Locking Ring slowly; making sure that the pressure has been released from inside the air valve prior to maintenance/removal from the pipeline.

The maintenance of the Multi-Functional Air Valve is performed for the 2 separate components:

### MAINTENANCE OF THE OPERATING VALVE - See Fig. 6

4. Follow instructions in the above section:  
**MANDATORY STEPS PRIOR TO MAINTENANCE**
5. Unscrew the Operating Valve Body (2).
6. Remove the Clamping Stem (5) and the Operating Assembly (4). Wash the inside of the Body, the Clamping Stem, the Operating Assembly, the Rolling Seal (3), and the O-ring (6) with clean water.
7. Gently wash and clean the sealing area inside the valve body.
8. Check the O-Ring visually for any defects. Replace if needed.
9. Check and make sure that the Rolling Seal is intact (not torn or cracked) and is positioned precisely in the middle of its groove in the Operating Assembly. Replace if needed.
10. The disc at the bottom of the Operating Assembly (Fig. 4) should be loose and move freely.  
**Do not tighten the holding screw.**
11. Reassemble the Operating Valve after maintenance.

### MAINTENANCE OF THE MULTI-FUNCTIONAL VALVE BODY - See Fig. 6

1. Follow instructions in the above section:  
**MANDATORY STEPS PRIOR TO MAINTENANCE**
2. Unscrew and remove the Locking Ring (13) together with the attached Operating Valve. Remove the Rolling Diaphragm Sealing Assembly (11) from the Body (14).
3. Wash the Body and the Locking Ring under clean water in order to remove coarse grime or accumulated scale.
4. Wash the Rolling Diaphragm Sealing Assembly under clean water and check the rubber parts for any tears. Replace the entire unit if needed.  
**Do not open screws of the assembly under any circumstances.**
5. Make sure that the drill hole is clean and the passage is open (Figure 5).
6. Make sure that there is no dirt or debris around the sealing area of the dynamic valve body.
7. Replace the assembly in the body, reassemble in reverse order, fasten and tighten the Locking Ring.
8. Open the isolating valve beneath the air valve, making sure that there are no leaks.

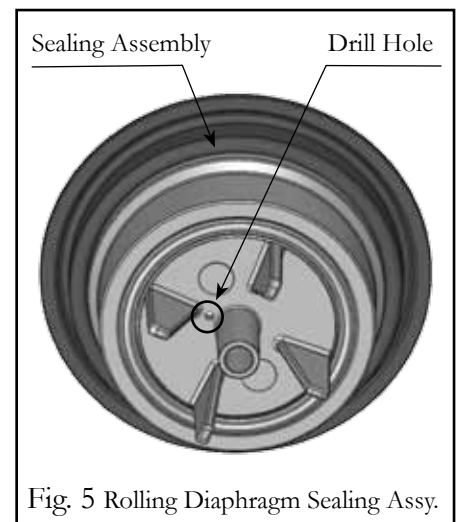
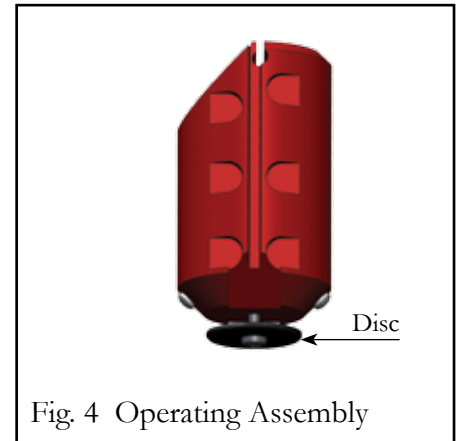
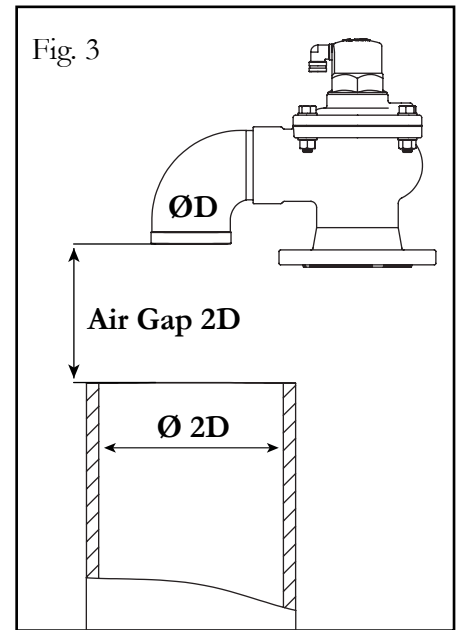

## PARTS LIST

No.	Part
-----	------

1.	Discharge Outlet
2.	Operating Valve Body
3.	Rolling Seal
4.	Operating Assembly
5.	Clamping Stem
6.	O-Ring
7.	Adaptor
8.	Ball Valve
9.	O-Ring
10.	Base Adaptor
11.	Rolling Diaphragm Sealing Assembly
12.	Supporting Ring
13.	Locking Ring
14.	Body
15.	Bug Screen

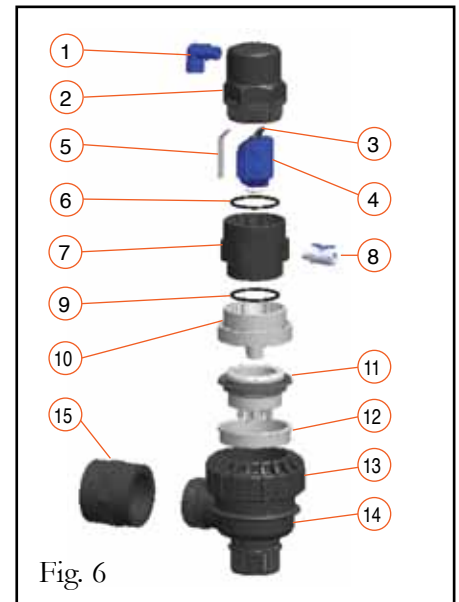

## TROUBLESHOOTING GUIDE

PROBLEM	REASON	SOLUTION
1. Leaking from the Discharge Outlet #2 (Fig. 1)	a. Debris or scale buildup on the Rolling Seal (2) b. Torn rolling seal.	Follow instructions above for: <b>MAINTENANCE OF THE OPERATING VALVE</b>
2. Leaking from the Discharge Outlet #1 (Fig. 1)	Debris or unwanted object caught in the Rolling Diaphragm Sealing Assembly (Fig. 5).	Follow instructions above for: <b>MAINTENANCE OF THE MULTI-FUNCTIONAL VALVE BODY</b>
3. Leaking from the Discharge Outlet #1 (Fig. 1)	Torn sealing assembly or diaphragm.	Follow instructions above for: <b>MAINTENANCE OF THE MULTI-FUNCTIONAL VALVE BODY</b>
4. Water flowing from the Discharge Outlet #1 and the flush valve (Fig.1).	Flush valve is not completely closed.	Close the flush valve tightly.

